



ASSEMBLY MANUAL

# 15x15 Inground Avyna

## In 7 Easy Steps



*DIY Installation Manual  
For a square Avyna  
In-Ground Trampoline  
Including assembly of the optional  
Safety Enclosures*

*For installation assistance or other information email, text or call:  
Trampolines.com 1-844-872-5867 or  
email questions to support@trampolines.com*

**Trampolines.com**  
SINCE 1997

# CONTENT LIST

	PARTS LIST	2 — 5
	HELPFUL TIPS	6
Step 1	ASSEMBLE YOUR FRAME	7 — 11
Step 2	ATTACH THE RETAINING WALL	12 — 13
Step 3	DIG THE HOLE	14 — 16
Step 4	PLACE AND LEVEL	17
Step 4.5	GRAVEL / DRAIN	18
Step 5	MAT AND SPRINGS	19
Step 6	BACK FILL	20
Step 7	SAFETY PAD	21
	ENCLOSURE (OPTIONAL)	22 — 28

# PARTS LIST

## TOP FRAME

**A1** K Tube  
TEPL-1515-fl-1141/A

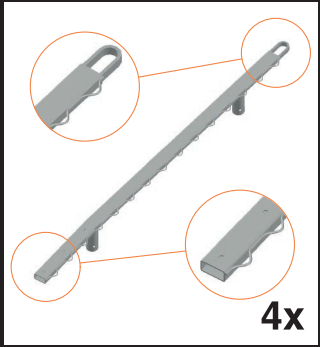

**A2** K Tube  
TEPL-1515-fl-1141/B

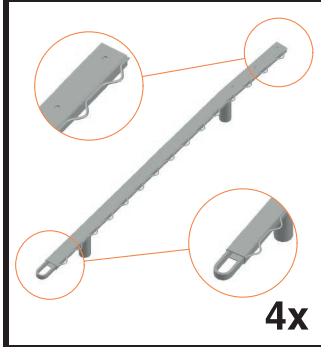

**A3** C Tube  
TEPL-1515-fl-1142

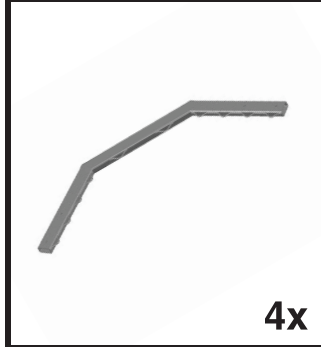

## TOP CONNECTORS

**B1** K Tube Connector  
TEPL-1515-fl-1141 / C



**B2** K Tube Connector  
TEPL-1515-fl-1141 / D

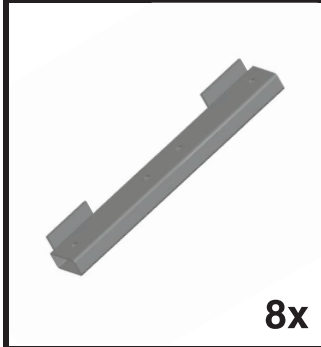

## BOTTOM FRAME

**T** I Tube  
TEPL-1515-fl-115

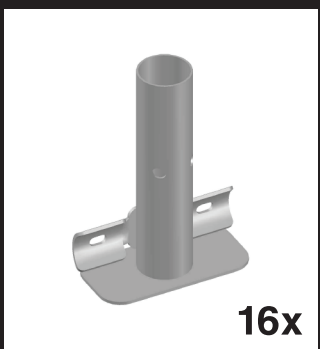

**C** C Tube  
TEPL-1515-fl-802 / C

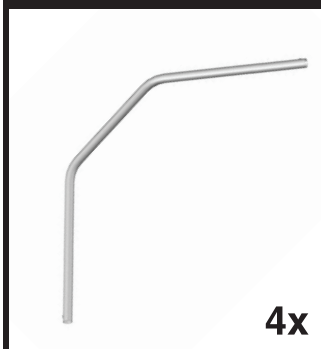

**D** I Tube Long  
TEPL-1515-fl-802 / B



**E** I Tube Short  
TEPL-1515-fl-802 / A

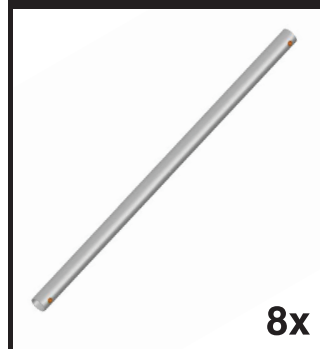

# PARTS LIST

## NUTS AND BOLTS



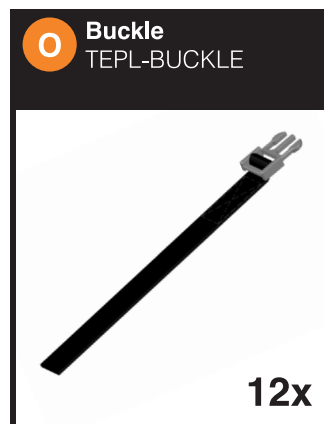
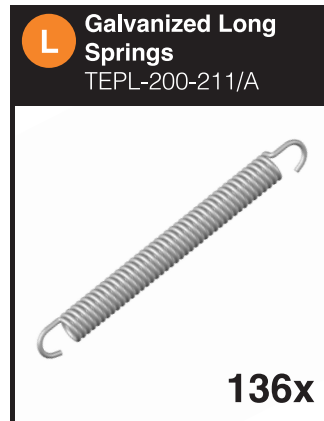

## OTHER PIECES



# PARTS LIST

## TOOLS IN THE BOX

**Q** Wrench  
  
**2x**

**R** Allen Wrench  
  
**1x**

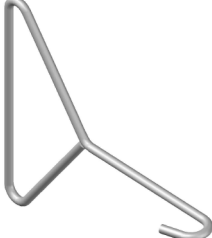
**S** Spring Tool  
  
**1x**

**U1** Short Measuring Tool  
2300-131/A  
  
**1x**

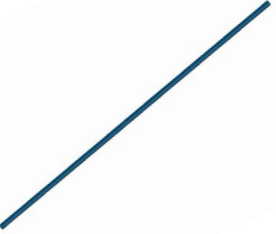



**U2** Long Measuring Tool  
2300-131/B  
  
**1x**

*On the following assembly pages, only letters (A, A2, B...) will be used to refer to the corresponding parts.*

# PARTS LIST

## ENCLOSURE PARTS

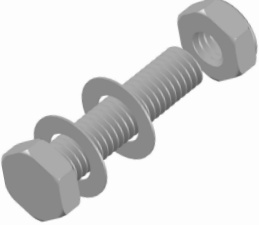
This is the parts list for the safety enclosure box. If you haven't bought the trampoline with an enclosure included, you can ignore this parts list.

<b>V1</b> Pole with Sleeve AVBL-1515-802 / A  <b>6x</b>	<b>V2</b> Pole w/o Sleeve AVBL-1515-802 / B  <b>6x</b>	<b>V3</b> Clamp CLAMP-TOOL-SN-1515B  <b>6x</b>	<b>W1</b> Safety Net ANBL-1515  <b>1x</b>
<b>F5</b> Screw M8 M8-30  <b>12x</b>	<b>Q</b> WRENCH  <b>2x</b>		

*On the following assembly pages, only letters (A, A2, B...) will be used to refer to the corresponding parts.*

## HELPFUL TIPS

- 1 Gather your tools** - it's always good to take inventory of what you have access to before you begin your project.
- 2 Know your team** - how many people you have to help you.
- 3 Plan accordingly** - this is the kind of project where the timing of it can change pretty dramatically depending on the resources at your disposal (whether in tools or manpower). Be sure to block off an appropriate amount of time to finish and be **GENEROUS** with it.
- 4 Shade is your friend** - the metal poles and springs can overheat quickly if left in the sun for too long, which can make installation even more difficult.
- 5 Watch the installation video** - before and during the installation, you can use the installation video if you need any step to be more clarified.

The installation video is for a rectangular trampoline (10x17). It's helpful and very similar to your 15x15 square trampoline, but there are some small differences.



Installation Video



# STEP ONE: ASSEMBLE YOUR FRAME



30-45 Minutes



- **Wrench to hold the bolts**  
You can use the Wrench that came with your box, or a Socket Wrench of your own that fits.
- **Allen Wrench** (Provided)
- **Gloves**



Need help?  
Scan me and go to step one

- 1 **Top:** Begin by connecting **A1** and **A2** using **B1** piece and secure in place by using the **F1** bolts. Do this 4 times until you have 4 identical long frame bars. After, add the **A3** corner tube in order to create the square top frame. Connect the corner tubes with the **B2** top connector and the **F1** bolts and your top frame is ready.

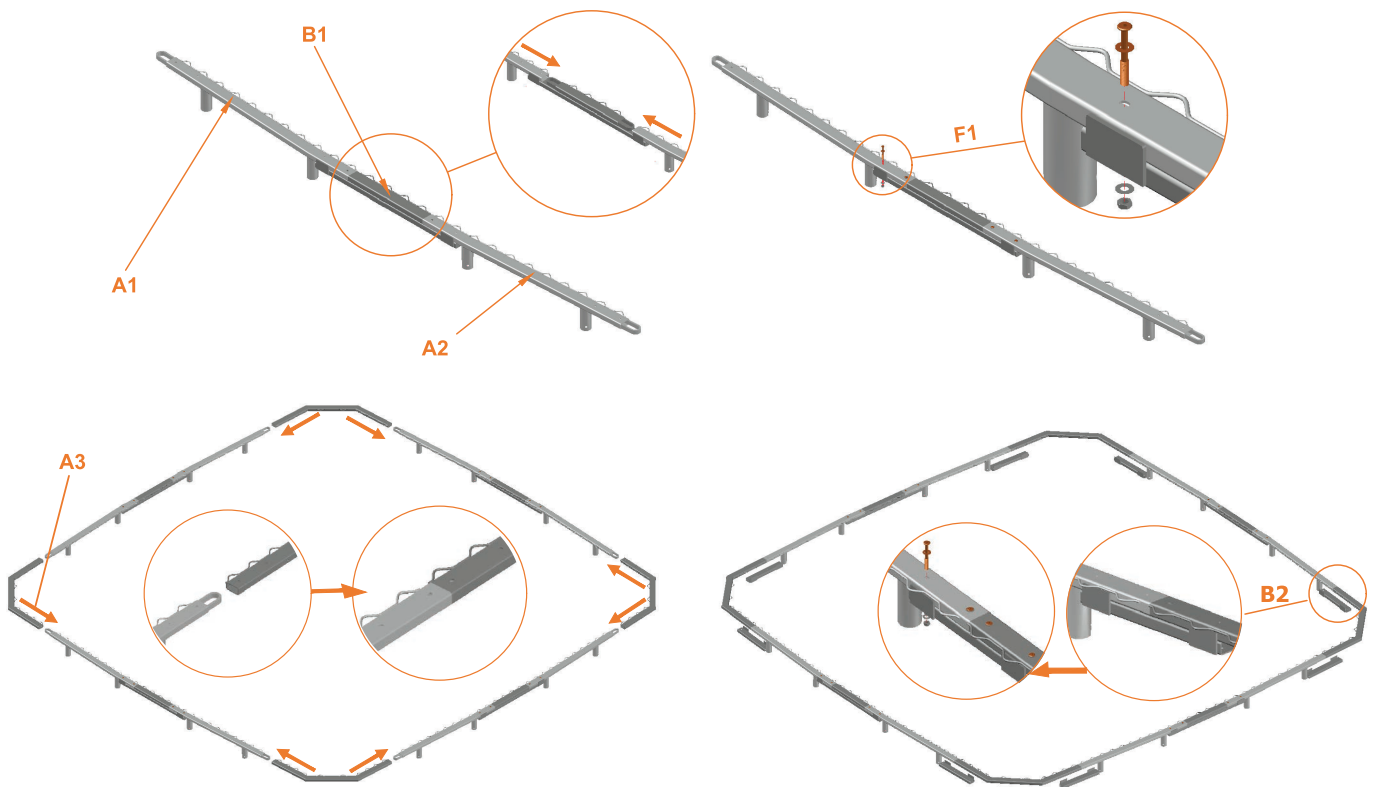

**NOTE:** The longer sides of the frame will appear to bow outwards. Don't worry! This is by design. When the springs and mat are added on, it will disappear.



## STEP ONE: ASSEMBLE YOUR FRAME

- 2** Connect the 12 BUCKLE STRAPS **O** to the TOP frame. You do this by bringing the safety pad **N** to your frame, flipping the pad upside down and fasten the BUCKLE STRAPS **O** to the TOP frame in the same place as where the buckle is on the safety pad. After this you won't need the safety pad **N** anymore until step 7.

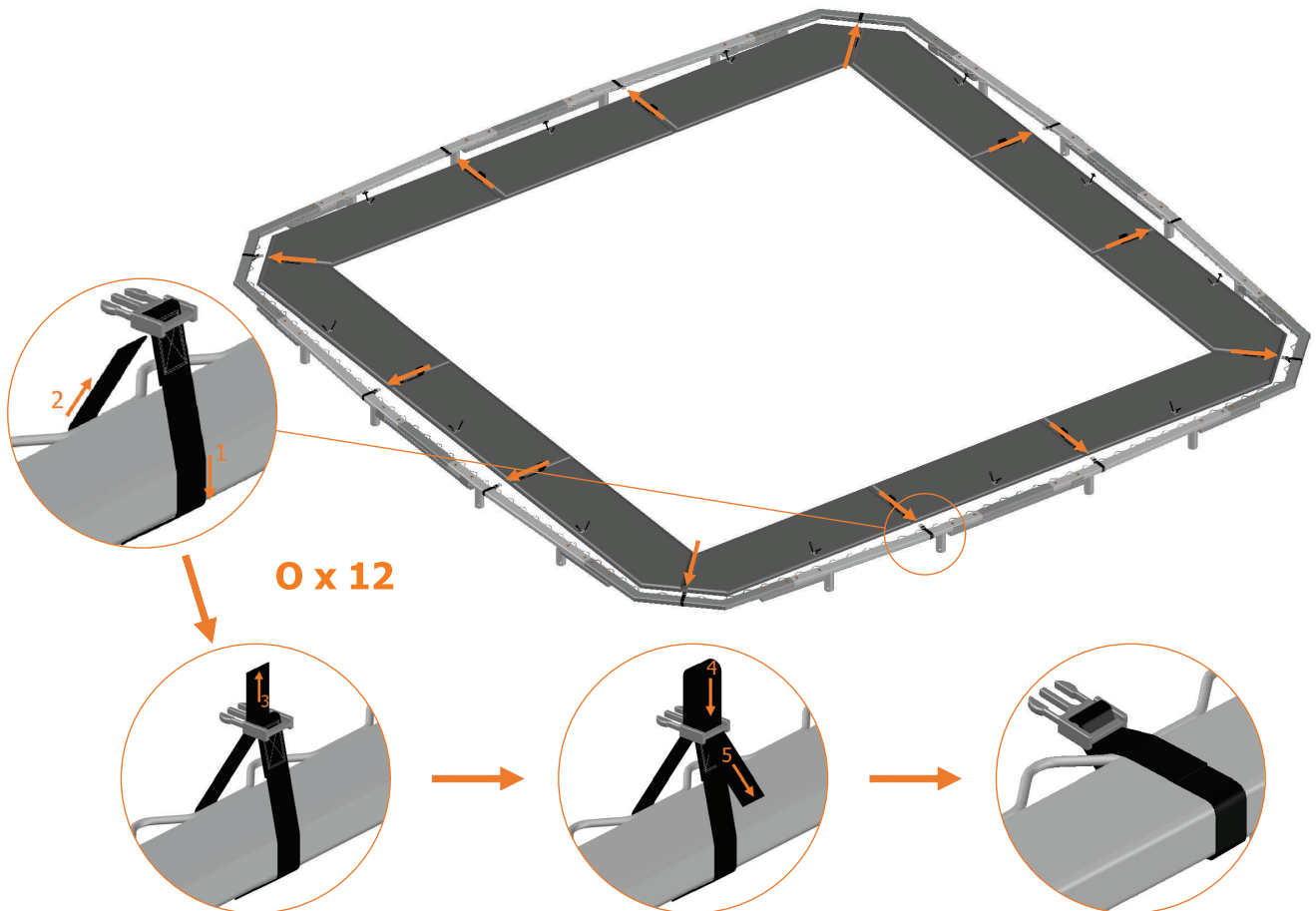

**NOTE:** It's important that the BUCKLES on these straps don't lay on top of the frame, but right next to it as in the picture below. Doing this right prevent you from damaging the buckles.

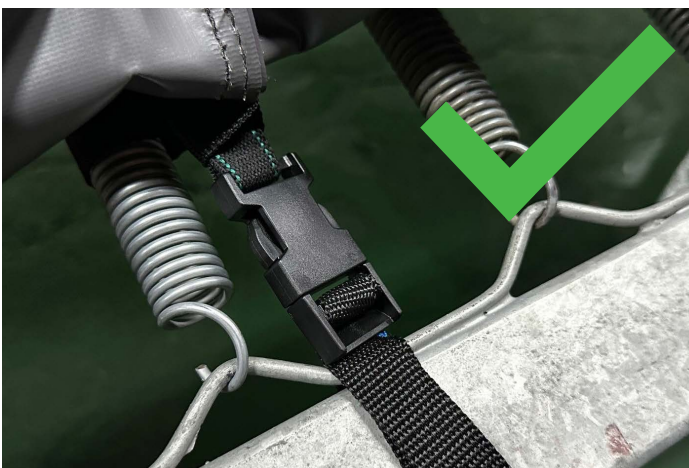

PLEASE PAY ATTENTION !

# STOP!

Have you purchased the 15x15 Inground **with an Enclosure?**  
**Please go to page number 22 to continue the installation.**

If you are not adding an enclosure, please ignore this sign and go to the next page.

## STEP ONE: ASSEMBLE YOUR FRAME

- 3 Middle:** Once the top part of the frame is secured, insert **T** into the neck joints along the upper frame. You'll want the curved bottoms of **T** to be on the outer edge of the frame. The **T** tubes have to be connected with the **F2** bolts.

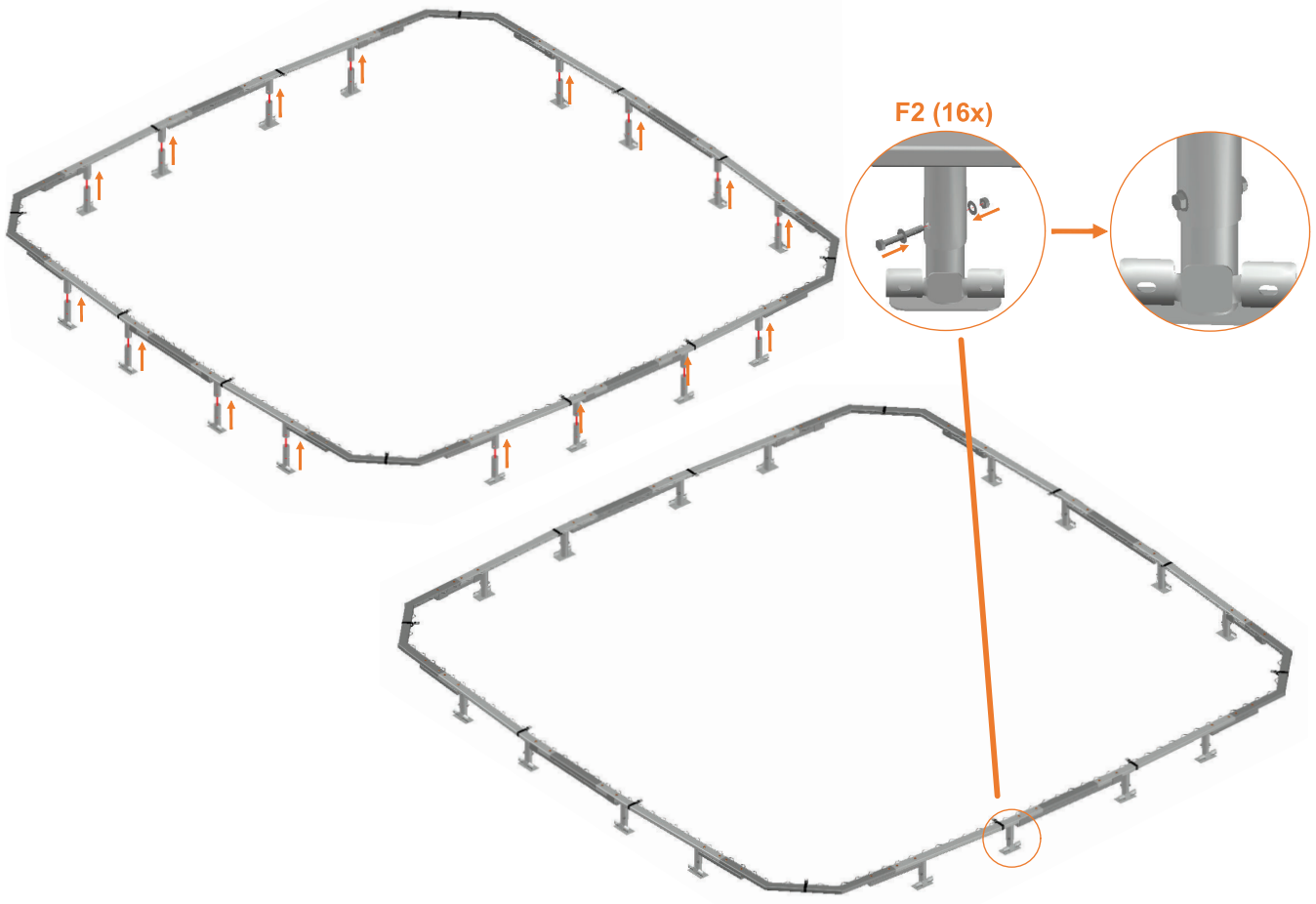

## STEP ONE: ASSEMBLE YOUR FRAME

- 4 Bottom:** Using **G**, connect **C**, **D** and **E** to form the bottom frame.

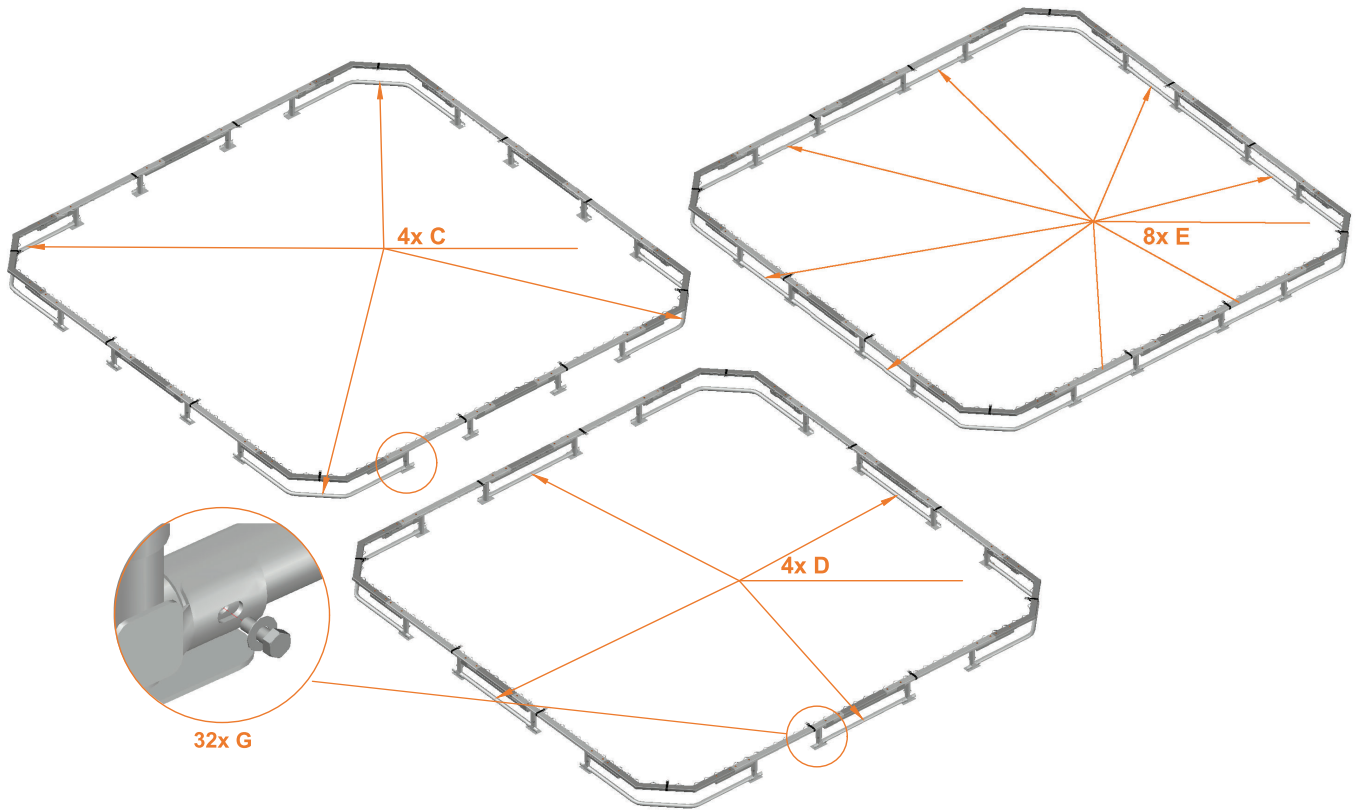

## STEP TWO: ATTACH THE RETAINING WALL



30 Minutes



Electric Screwdriver or Phillips-Head Screwdriver



Need help?  
Scan me and go to step two

**SET UP:** While unraveling the retaining walls, you will see that there are four corner pieces. The pieces are meant to overlap as you attach them.

- 1 Start with 1 of the 4 panels **I** in the corner. Secure the panel with **H** to the pre-drilled holes in the frame. Be aware that all ends of the panels have an overlap with the next corner panel.

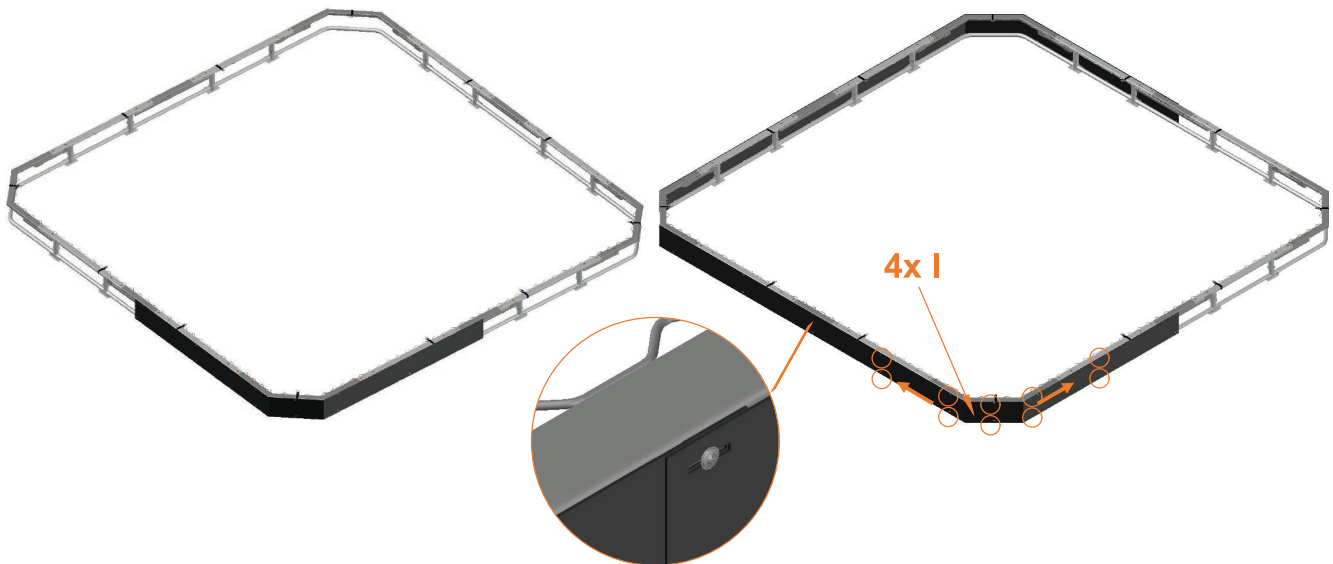

**Tip #1:** First attach the bottom part of each panel with the self tap screws. Once you finish that process, you do the same with the upper part. This will make the process easier.



## STEP TWO: ATTACH THE RETAINING WALL

- 2** Remaining Panels: Using the **H**, work your way around the remainder of the frame. Be sure to make the wall as flush with the frame as possible. This might require occasionally backtracking and loosening portions of the wall to get rid of sections that are protruding or not flush.

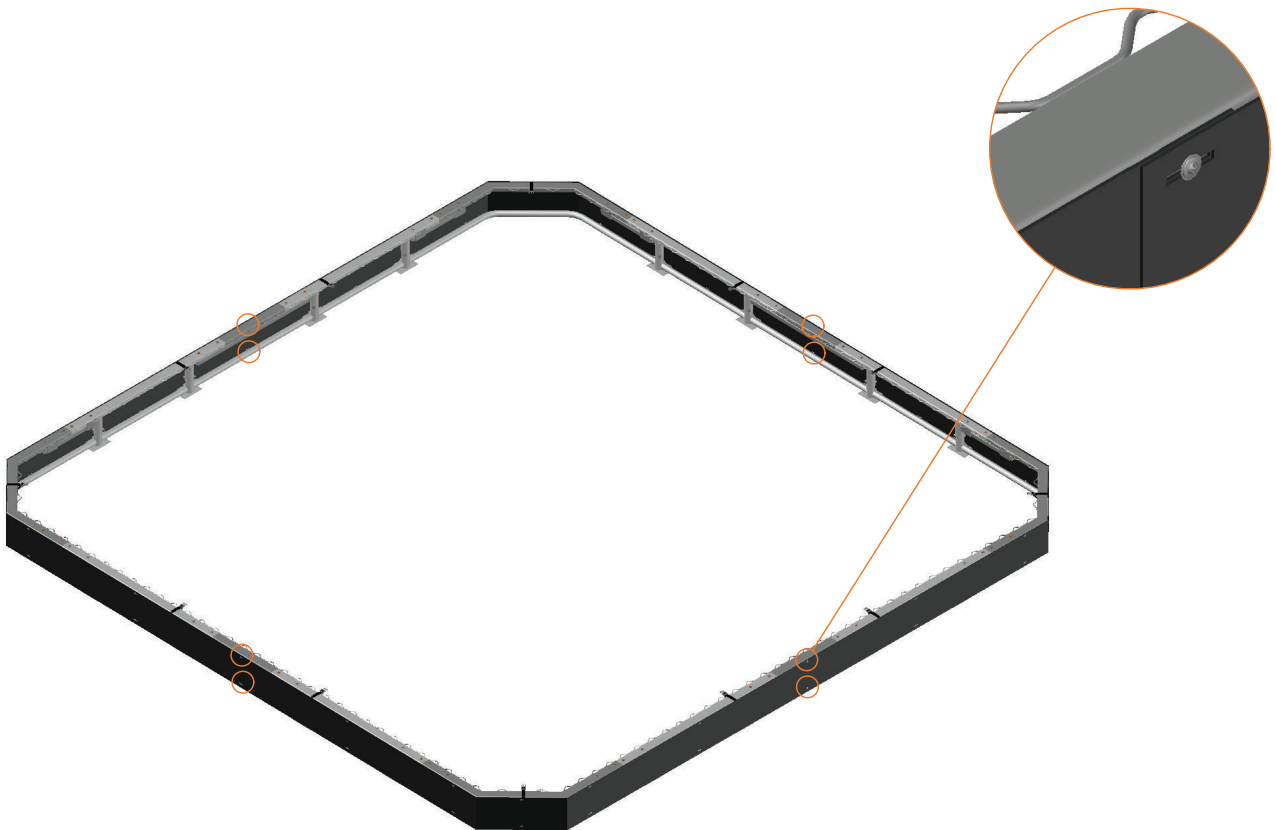

**LED Lights:** If you purchased the LED lights this would be the best time to attach them to the inside of the trampoline retaining wall.



## STEP THREE: DIG THE HOLE



2 - 8 hours

The time it takes to dig the 15x15 hole can vary depending on the number of people and accessibility to tools. A landscaper with access to an excavator might be able to have the hole dug in 2-3 hours. A team of people with shovels will take more time. Plan accordingly with the resources available to you.



Tools may vary depending on your accessibility. At the bare minimum you will need:

- **Shovels**
- **Gloves**
- **A level**
- **A tape measure**
- **Pick Axe**

Other tools like a spirit level or excavator / mini digger will help speed the process up.



Need help?  
Scan me and go to step three

**SET UP:** Digging the hole can be the trickiest and most time consuming part of this experience. But don't worry, we're here to help! By observing the graphic, the steps that follow and utilizing the two measuring rods that came in the box, you'll have the perfect hole for your trampoline! Because the Avyna 15x15 utilizes a modified retaining wall system that sits on a shelf, you'll essentially be digging two holes. See the following graphic.

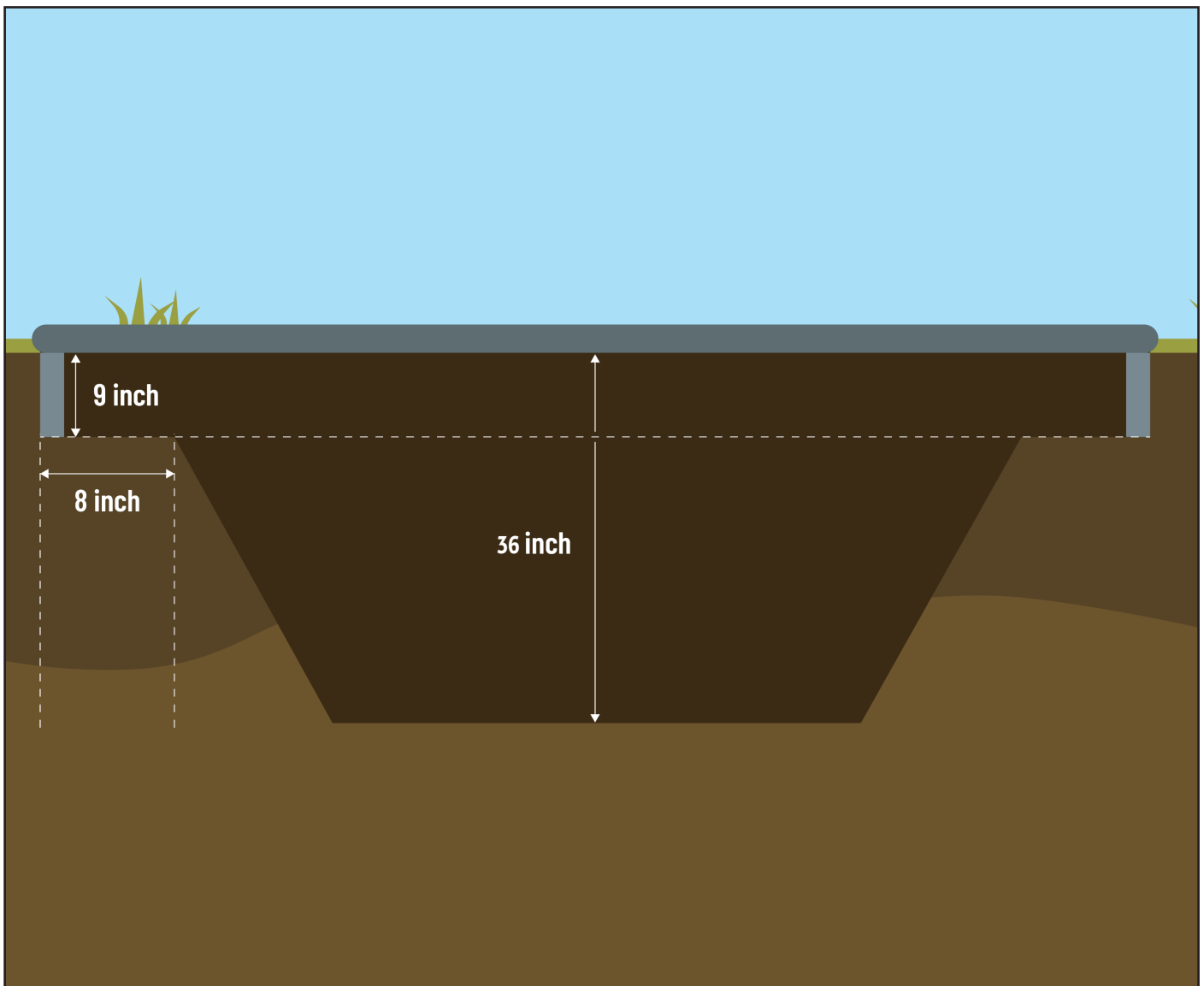

## STEP THREE: DIG THE HOLE

**Tip #2:** Though a can of “grass spray” is not needed for marking your trampoline digging area, we find that it can be an incredibly helpful tool!

- 1 Outline:** Using your assembled frame as a guide, you’ll want to mark out the area that you’ll be digging. With the Avyna frame, you can be pretty exact, but we recommend usually having about 2-4 inches on the outside of the frame that will be backfilled later on. It is important that these inches are not included in the 8 inch shelf the frame will be resting on.



- 2 Dig Top Hole:** After marking out your trampoline, begin by digging the upper hole for your retaining wall and frame. It should be 9 inches deep. Remember to use your Short Measuring Rod **U1** to help with that distance! You’ll want to save about 2-3 wheelbarrows full of dirt to help backfill the frame later on.



## STEP THREE: DIG THE HOLE

**Tip #3:** Though it is not necessary, some people like to save portions of the removed turf and grass to add back into the area on the outside of the frame post installation.

- 3 Dig Inner Hole:** Measuring about 8 inches away from the edge of the wall, begin to dig your inner hole. It should be  $36-9=27$ " deep minimum, to make a total of 36" minimum from the top of the hole to the bottom. You'll want to dig the slant of your hole at about a 45 degree angle. If you plan to add gravel at the bottom, dig your hole 2-3" deeper to accommodate for the gravel. The Long Measuring Rod **U2** and Short Measuring Rod **U1** stacked on each other will make 38", which is the length you would want if adding gravel.



## STEP FOUR: PLACE AND LEVEL



15 minutes - 1 hour



- Gloves
- Shovel



Need help?  
Scan me and go to step four

**SET UP:** Once the retaining wall is attached to your assembled frame, and your initial hole has been dug, it's time to make sure it's level and your trampoline is as flush with the ground as possible.

- 1 Placing the Frame:** Using at least two people, you'll want to lift the frame into the hole and onto the shelf you've created.
- 2 Checking Levels:** Check to make sure that your trampoline is level and as flush with the ground as possible.

**If it isn't level** → Work to remove or add dirt to the necessary areas along the frame. Some people like to take the frame out of the hole while making adjustments, while others like to keep it in. It is totally up to your comfortability level.

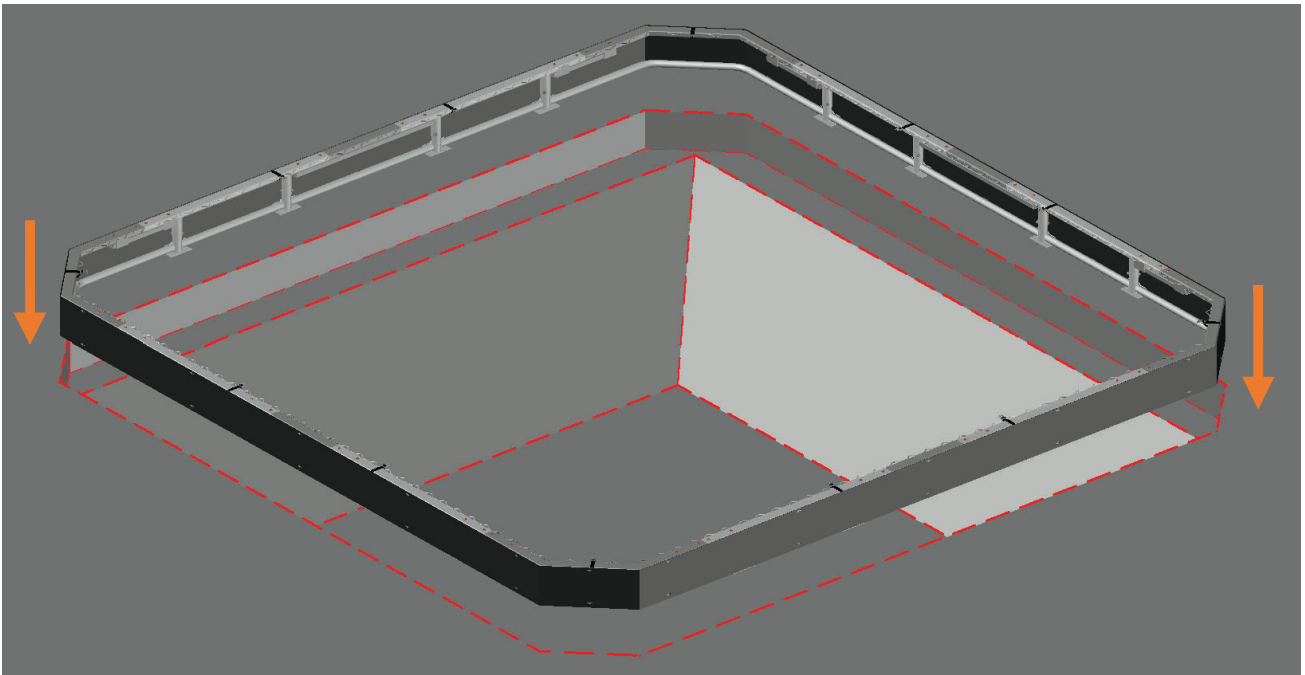

## STEP FOUR AND A HALF: GRAVEL / DRAIN

**INFO:** A common question we receive is about drainage. In most instances, water is just absorbed into the ground like it would before the soil was disturbed. That being said, down below are some options for those who this is a concern for or those who live in rainier than usual climates.

### Weed Barrier

- A simple weed barrier is a great way to combat weeds and other plants from growing underneath your trampoline.
- Who we recommend it for: Everyone! No matter the climate.
- If case you use the Cross Bar in your frame, please pay attention:

First add the crossbar to the frame to make sure you took out enough dirt for this cross bar connection. If well set, take the cross bar and the trampoline out of the hole, place the weed barrier and put the trampoline + cross bar back in its correct position.

### Gravel

- 2-3 inches of gravel is a great way to help water get distributed back into the soil. It also adds a nice clean look to it.
- Who we recommend it for: People in climates with moderate to heavy rainfall. OR. Anyone who is looking for a cleaner looking trampoline hole.

### Soak Away

- A soak away drain is a really effective tool for distributing large amounts of water when it rains.
- Who we recommend it for: Only people in areas with heavy rainfall or high water levels in their soil
- For high water tables or poor drainage soil you may need to install a sump pump. Consult with your landscaper or installer.

**Weed Barrier**



**Gravel**



## STEP FIVE: MAT AND SPRINGS



15 - 30 Minutes



- Gloves
- Avyna Spring Tool



Need help?  
Scan me and go to step five

- 1 Starting in the corners, you'll want to attach all the Short Springs **M** to their respective loops in frame and Jump Mat **K**. There should be 8 corner springs total.
  - 2 Attach a Long Spring **L** on the North, South, West and East side of the frame and Jump Mat **K**. Begin filling in the remainder of the springs. Utilize the Spring Tool **S** if you come across a spring you're struggling to stretch out.
- Tip #4:** Keep an eye on the tension and make sure it stays even. It's helpful to do this step with a partner.
- 3 You will see the Jumping mat has 12 loops under its protection flap. Put the springs **L** through those loops and connect them with the frame. This prevents the flap to fold while jumping.

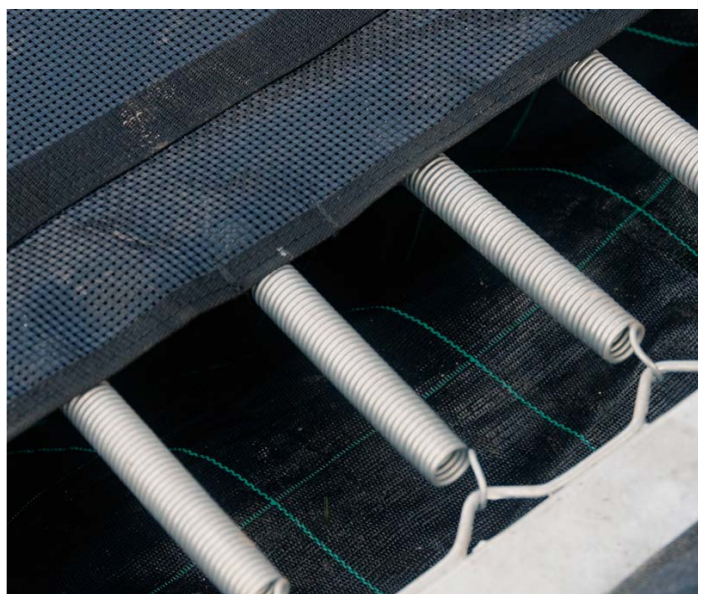
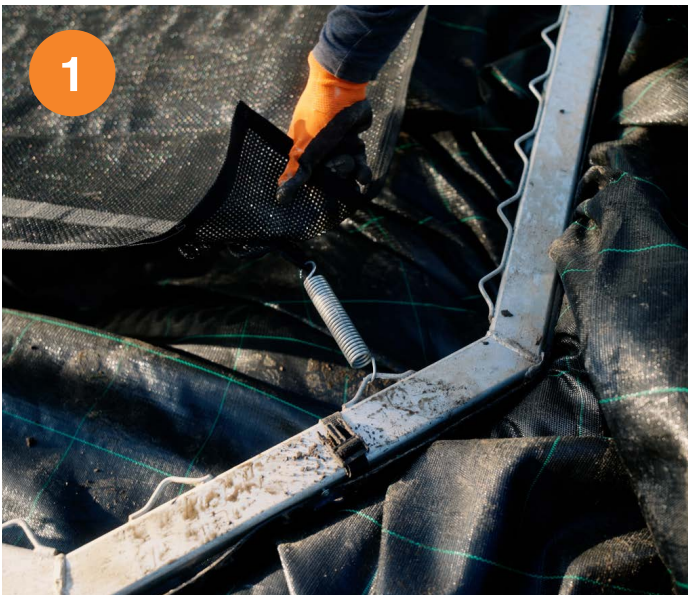

## STEP SIX: BACK FILL



20 Minutes



- Gloves
- Shovel



Need help?  
Scan me and go to step six

**SET UP:** Now that your frame is in the ground with the mat and springs, you should notice that there will be a considerable gap between the edge of the frame and dirt hole you made. It's time to get those wheelbarrows of dirt you saved earlier and get filling!

- 1 Backfill:** Making your way along the edge of the trampoline, fill in the gaps with soil, packing it down tightly as you go with your foot, **do not use equipment to pack the dirt as this may cause damage to the frame and trampoline.** By the end, there should be NO GAPS between your trampoline frame and the rest of your yard.
- 2** If you used **weed barrier** to cover your hole, this is the right moment to cut it to size.
- 3 Sod:** If you saved grass from earlier, lay it down as the top layer on your tightly packed dirt.

**Tip #5:** Have someone jump on the trampoline as you backfill the dirt around the frame wall. This will help to further fill any gaps and ensure the trampoline is tight within the ground.

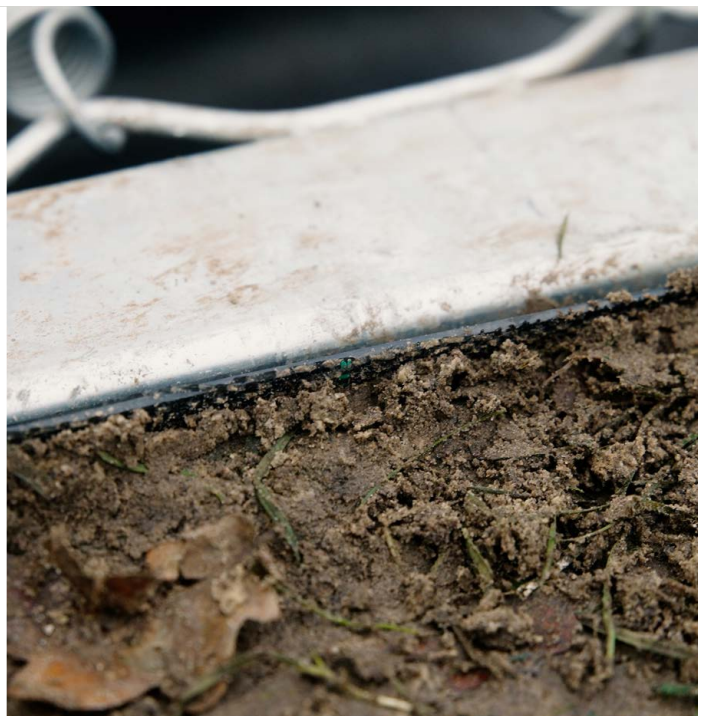

## STEP SEVEN: SAFETY PAD



15 - 20 Minutes



• Screwdriver



Need help?  
Scan me and go to step seven

**SET UP:** Now that your trampoline has been backfilled, you just need to attach the Avyna Safety Pad and your trampoline will be fully operational!

- 1 Take the pad **N** and cover the springs with it. Every stitching part has a loop at the bottom. Take out the corresponding spring, put it through the loop and attach it again to the frame.



- 2 Connect the buckles: on the outside of the loops, you will see the buckle connectors. You can easily connect them to the buckle straps **O**, used in step one, in order to attach them to the frame.



- 3 You finish this step by connecting the bungees **P** to the frame. Those bungees are connected to the pad already, you will find them in the center of every section. Use a screwdriver or something similar to create some space between the frame and the retaining wall to put the bungee **P** through.

**Tip #5.5:** When it's difficult to grab the bungee with your hands due to limited space, use the SPRING - TOOL S to loop the bungee around the frame.

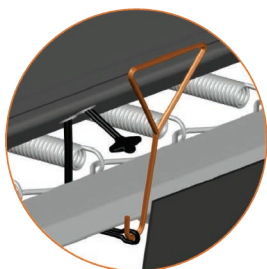

## ENCLOSURE (OPTIONAL)



Need help?  
Scan me and go to  
the optional step

- E.1** In STEP ONE (page 7-8) you assembled the TOP frame. Now you will attach the Middle frame. Insert **T** into the neck joints along the TOP frame. You will want the curved bottoms of **T** to be on the outer edge of the frame. Take the 6 TOOL-CLAMPS **V3** and connect TOP frame, **T** and **V3** together with the **F2** bolts.

**Be aware that you place the 6x V3 CLAMPS into the 3 CORNER neck joints. If you do this wrong, you won't be able to install your enclosure. ★**

- E.2** Once you connect them, fix the **V3** TOOL-CLAMPS also with the additional bolts and nuts **F5**.

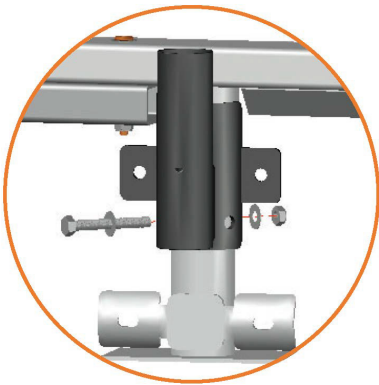

**E.1**

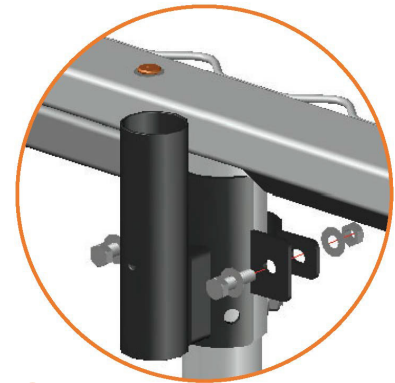
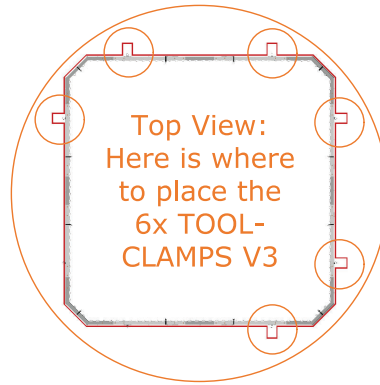

**E.2**

- E.3** Bottom: Using **G**, connect **C**, **D** and **E** to form the bottom frame.

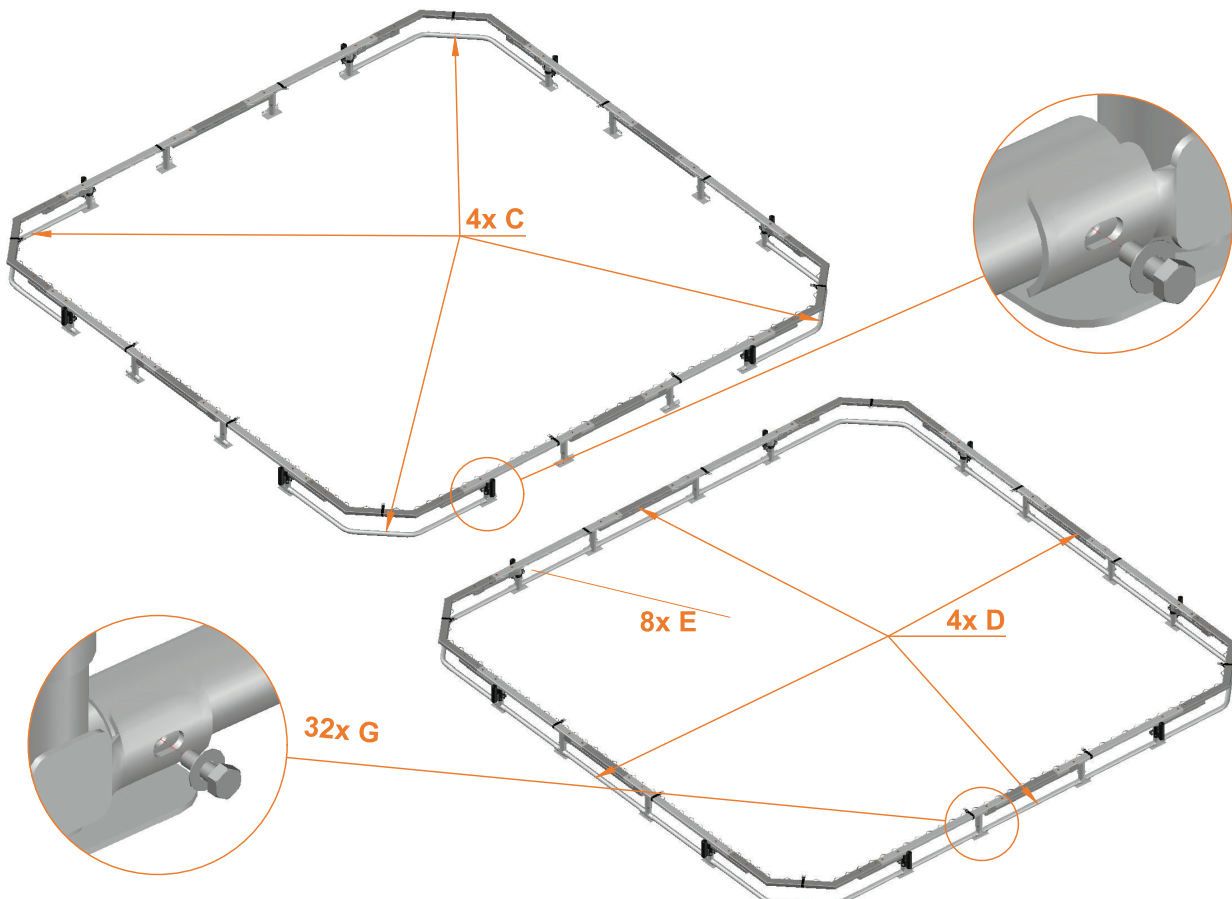

## ENCLOSURE (OPTIONAL)

### E.4 Attach the retaining wall

**SET UP:** While unraveling the retaining walls, you will see that there are four corner pieces. The pieces are meant to overlap as you attach them. Before you start to attach them, press the pre-printed oval holes out of the panels.

Start with 1 corner Panel I and attach it with H to the pre-drilled holes in the frame. Be aware that all ends of the panels have an overlap with the next panel.

While attaching the panels to the frame, make sure you put the pre-printed holes through the TOOL-CLAMPS V3.

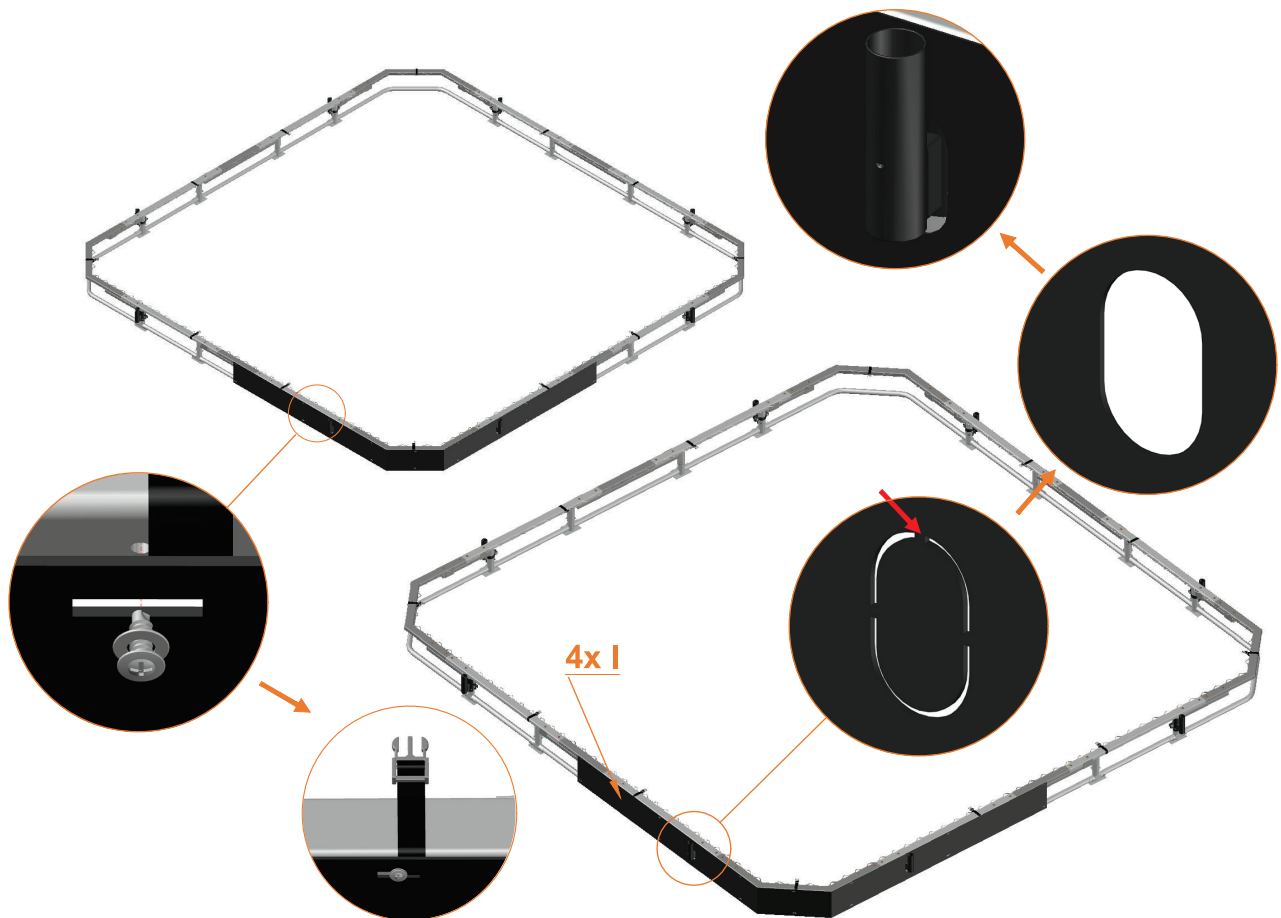

**Tip #6:** First attach the bottom part of each panel with the self tap screws. Once you finish that process, you do the same with the upper part. This will make the process easier.



## ENCLOSURE (OPTIONAL)

- E.5** Remaining Panels: Using the **H**, work your way around the remainder of the frame. Be sure to make the wall as flush with the frame as possible. This might require occasionally backtracking and loosening portions of the wall to get rid of sections that are protruding or not flush.

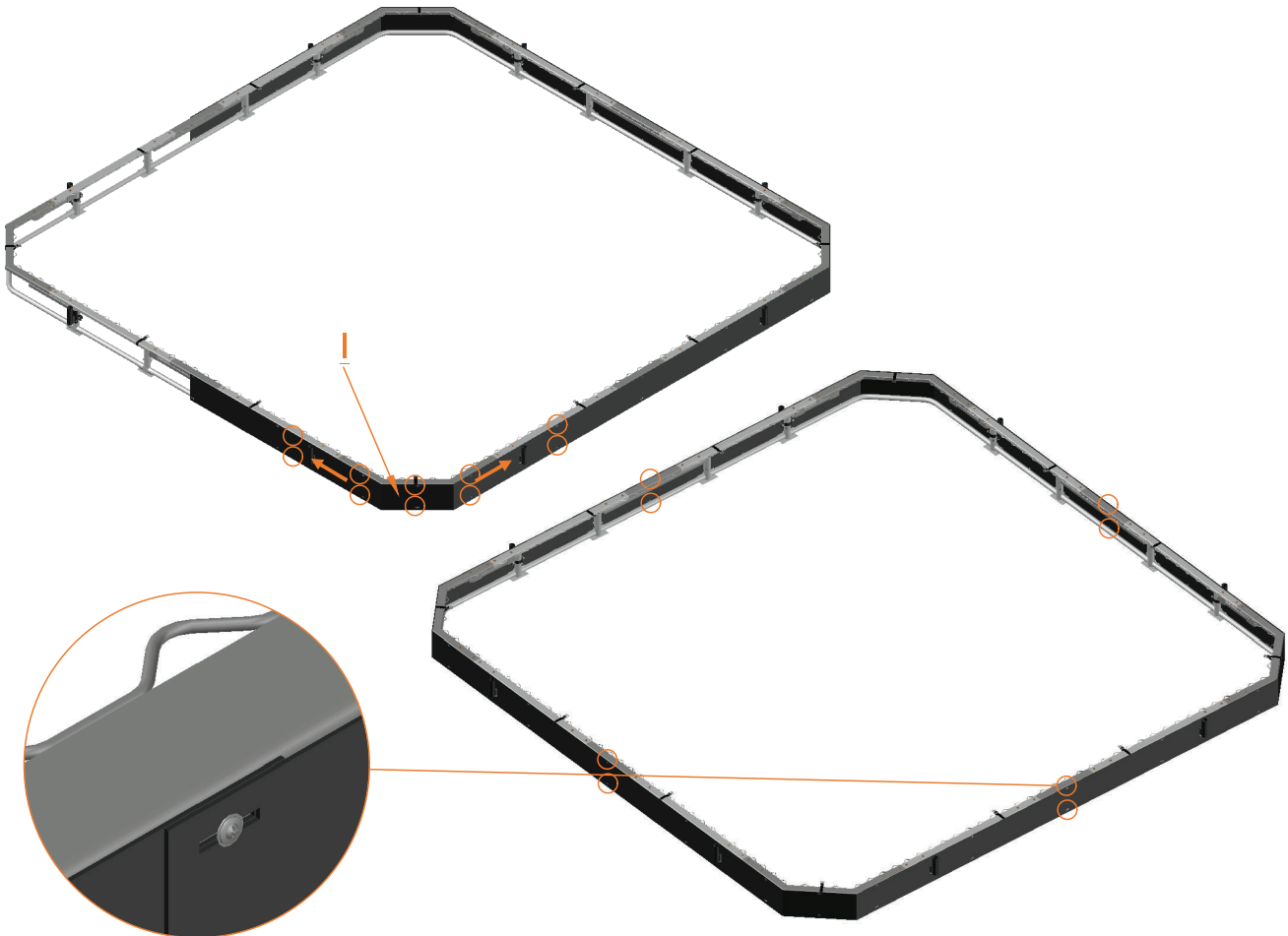

**LED Lights:** If you purchased the LED lights this would be the best time to attach them to the inside of the trampoline retaining wall.



## ENCLOSURE (OPTIONAL)

**E.6 Dig the hole:** To complete this step, you will need to go back to pages 14, 15 and 16. Once you finish that, go back to this page and do this additional step. Make sure you take out some additional dirt for your **TOOL-CLAMPS (V3)**. Down here you will see how to do that:

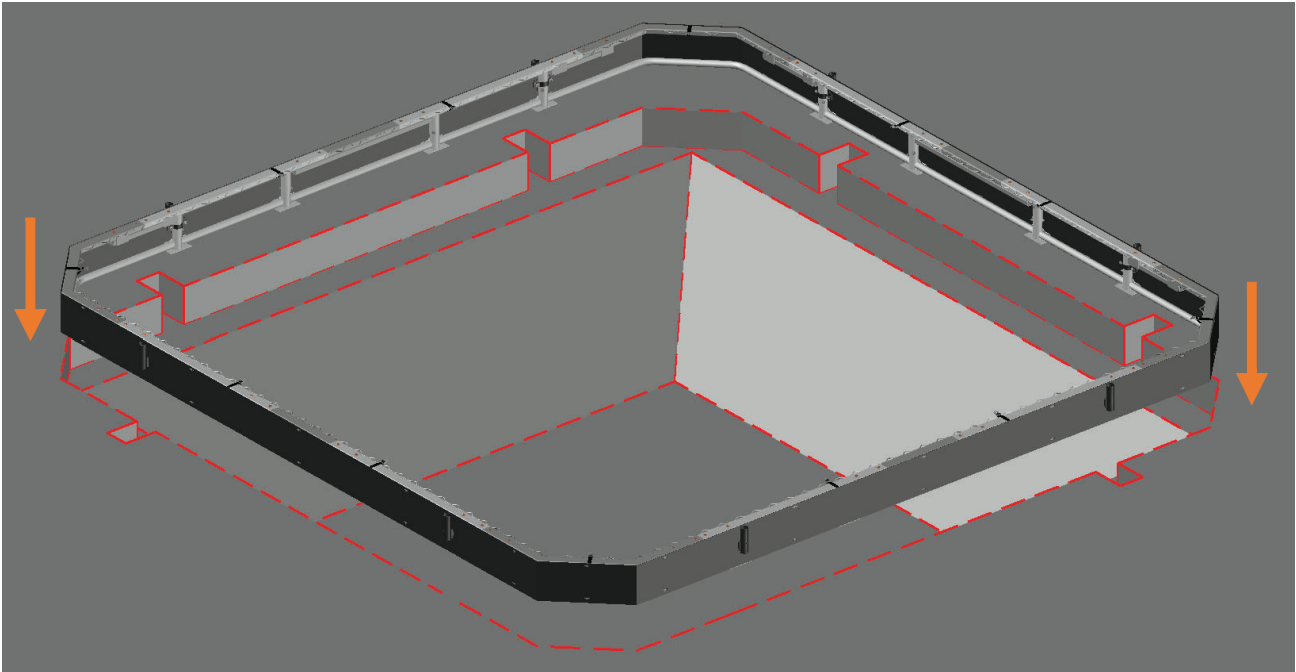

**Important:** as you have to take out some additional dirt for your **CLAMPS**, here is when you decide the position of your enclosure!!!



After doing this, your trampoline frame is ready to place and level.

## ENCLOSURE (OPTIONAL)

- E.7** Follow STEPS 4, 5, 6 and 7 on the pages 17 - 21. When you finish those steps, come back to this page in order to connect the net.
- E.8** **Build the net poles.** Click **V1** and **V2** together to create the complete enclosure pole (6x). You will hear a 'click' when both tubes are connected. Unfold the net completely and go to the next page.

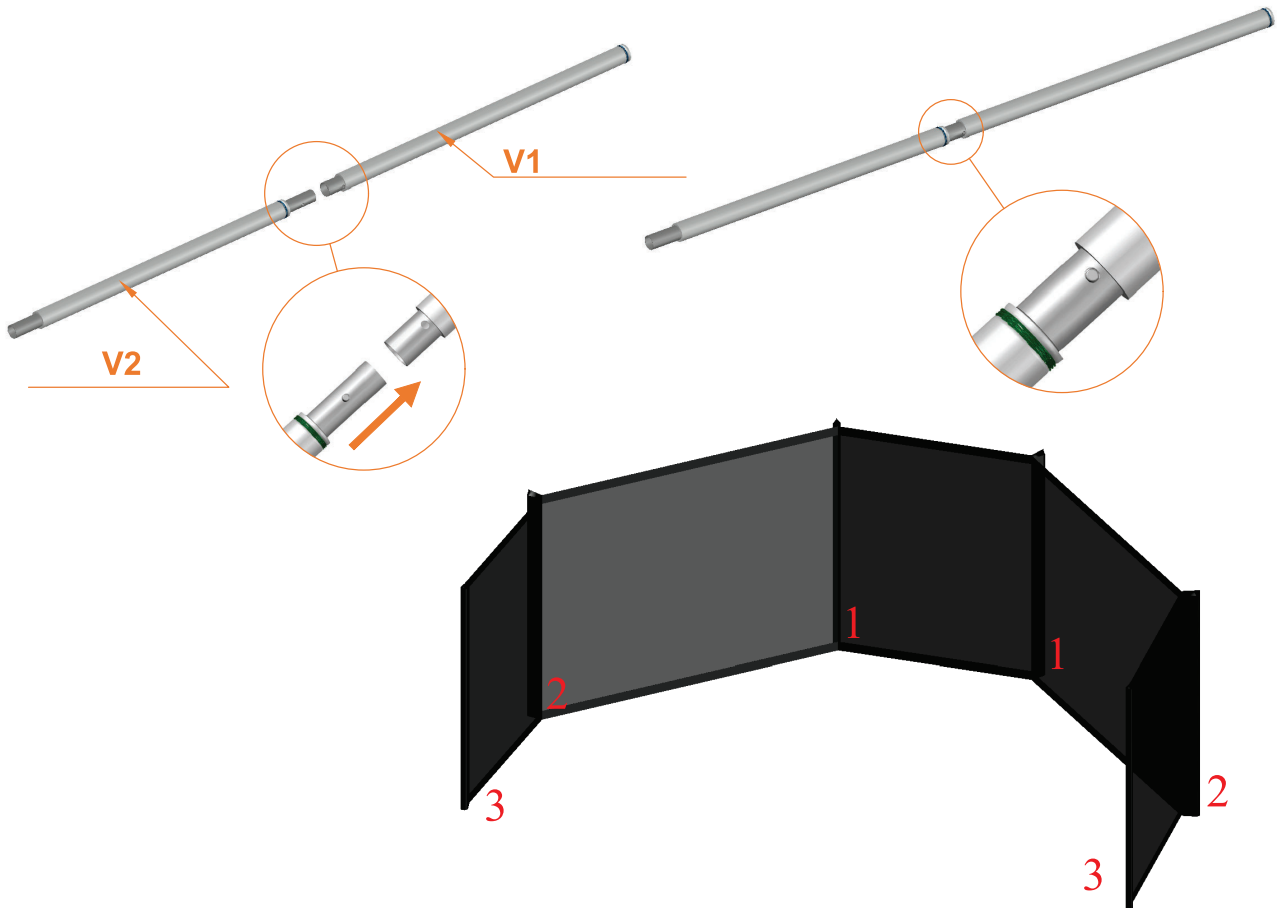

## ENCLOSURE (OPTIONAL)

- E.9** Add the poles to the net **W1**, starting in the middle of the net. Make sure you insert **V1** into the sleeve of **W1**, and use **V2** to secure the pole in the clamps **V3**. When you finish with the two middle poles (see numbers 1 in the figure below), do the same with the numbers 2 and the numbers 3.

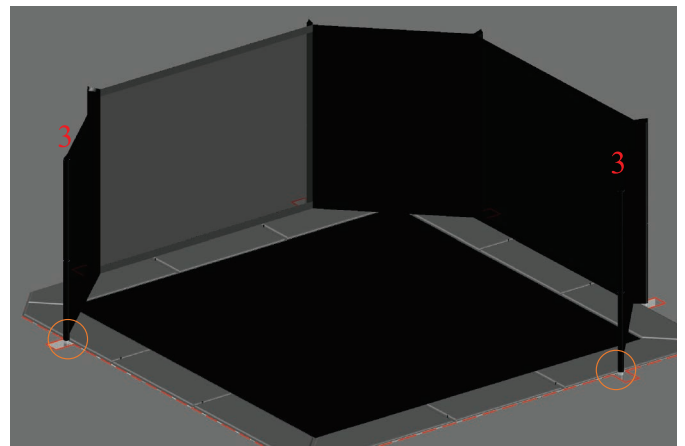
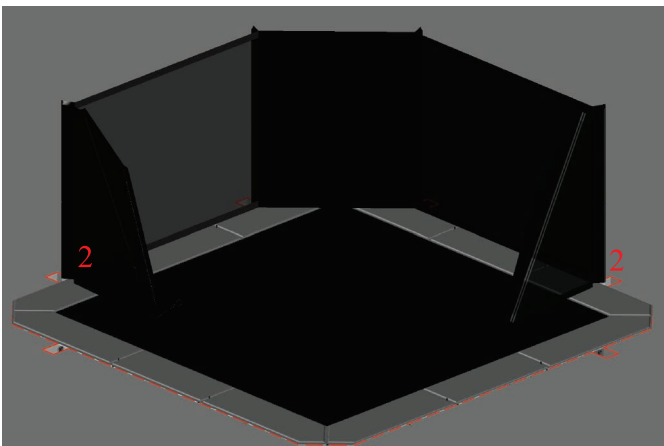
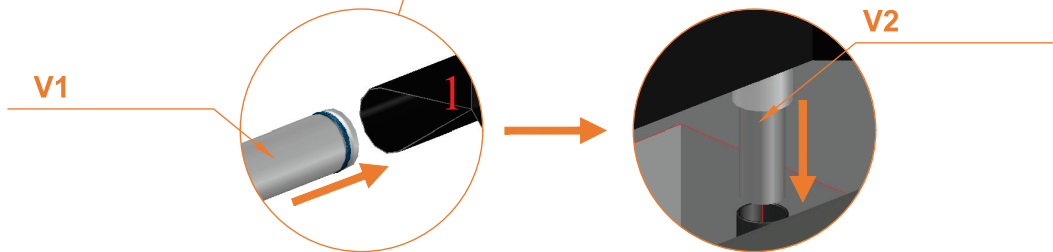
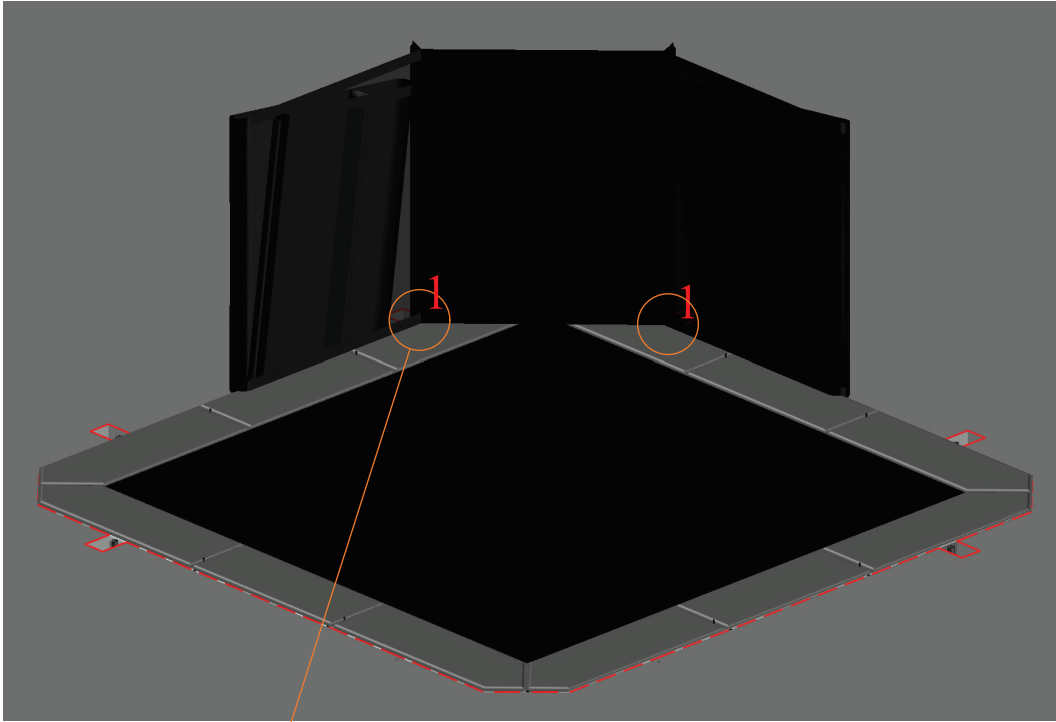

## ENCLOSURE (OPTIONAL)

YOU DID IT! ENJOY THE TRAMPOLINE!

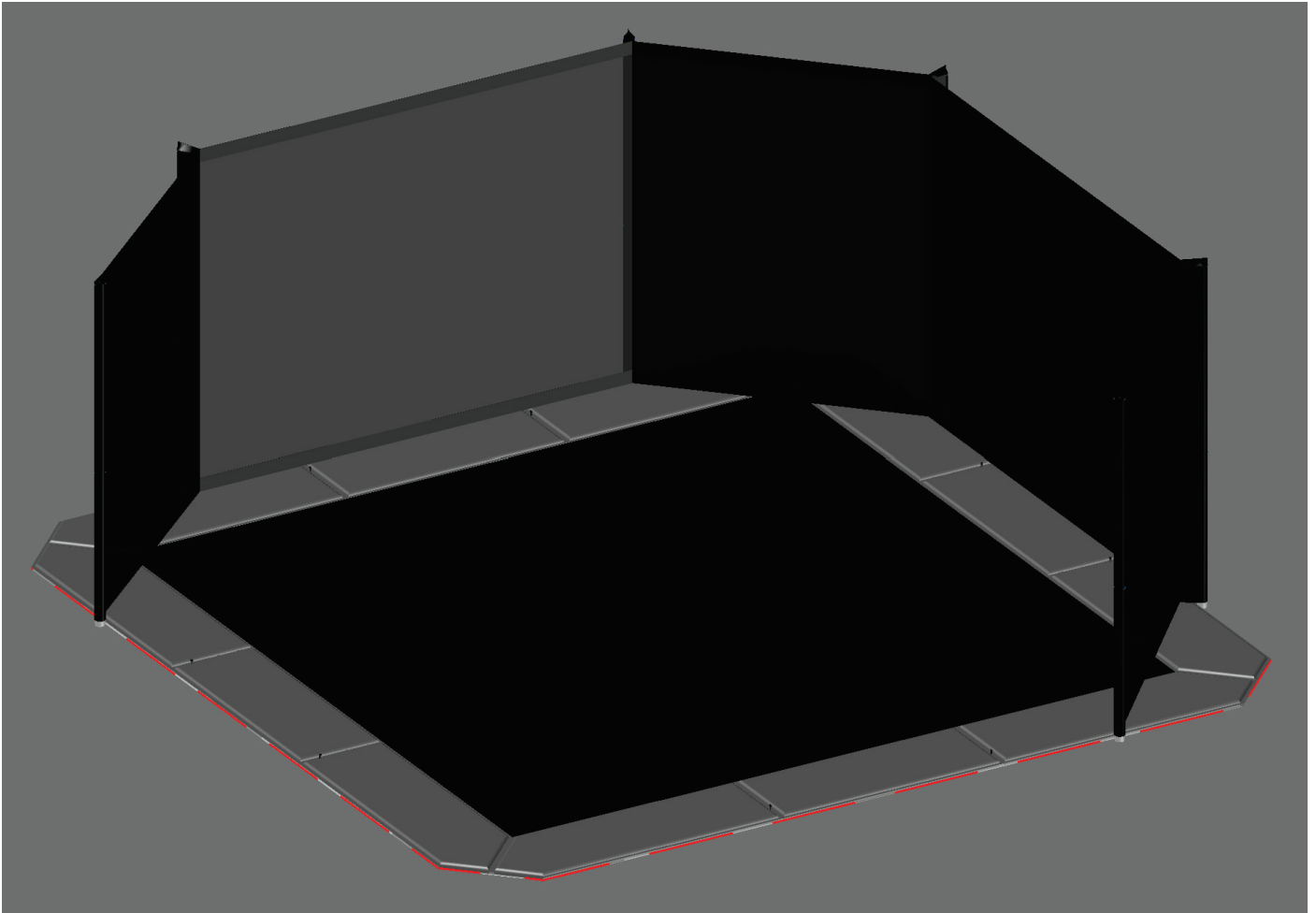



15x15 Avyna In-Ground Trampoline is available at  
[www.trampolines.com](http://www.trampolines.com)

*For installation assistance or other information email, text or call:  
Trampolines.com **1-844-872-5867** or email questions to*

**[support@trampolines.com](mailto:support@trampolines.com)**

